



# GLASS CRUSHER

MODEL

# 620



- ▶ Rated capacity: 3 to 4 tons per hour
- ▶ Crushes up to and including one gallon containers
- ▶ Processes full or partially filled containers
- ▶ Factory-direct parts and service

A high volume glass crusher designed for long life and trouble-free operation. This model is capable of handling full or empty bottles. Conveyor designed with side flanges on belt and cover rails to contain material. This feature has proven to greatly extend the life of the belt, eliminating some costly routine maintenance found on other crushers.



MODEL

# 620

## SPECIFICATIONS

- ▶ Machine constructed of heavy gauge steel
- ▶ Designed for easy maintenance and upkeep
- ▶ Replaceable crushing chamber
- ▶ Reduces volume by 80%
- ▶ 1/2 HP crusher motor
- ▶ 1/2 HP conveyor motor
- ▶ Crushed glass weight = 80 lbs./cu. ft.
- ▶ 16" wide conveyor bed
- ▶ Features self-cleaning tail pulley
- ▶ Replaceable rubber discharge shroud
- ▶ Hardened replaceable crusher bar
- ▶ Side flange belt

## DIMENSIONAL INFORMATION

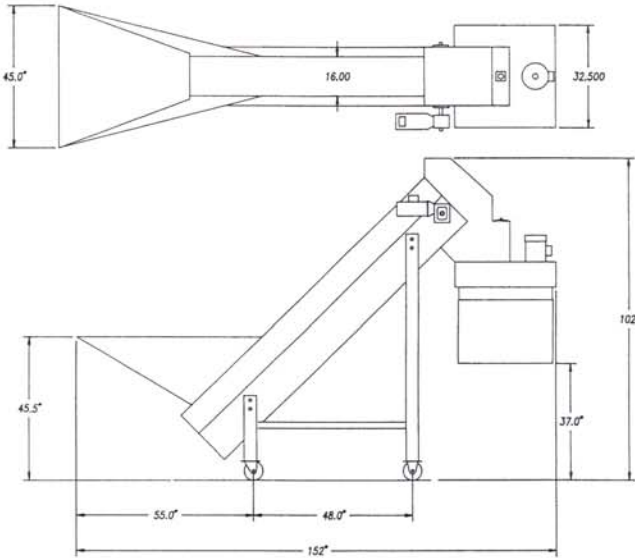

## OVERALL DIMENSIONS

**Length:** 12'8"  
**Width:** 45"  
**Height:** 8'6"  
**Weight:** 1,188 lbs.

### 1 Year Written Warranty

All Prodeva brand equipment carries a warranty on workmanship and materials, provided equipment is used for its intended use and maintained properly.

We reserve the right to repair or replace parts at our option. Ask for further details. Prodeva, Inc., also reserves the right to improve or alter products without prior notice.

### PRODEVA PROFILE

PRODEVA, Inc., with nearly 40 years experience in the size reduction field, offers a complete line of crusher and shredder models for processing bottles, cans (aluminum or steel), plastic and glass. Our equipment is used world-wide for recovery, recycling, scrap, and disposal facilities, both public and private. All are engineered and field-tested for profitable operations.

Should you have any questions or need additional information on the Model 620 or any other Prodeva products, please feel free to call us. Prodeva offers a wide range of recycling equipment as well as conveyor systems.



Since 1958

**PRODEVA, INC.**

100 Jerry Drive, Jackson Center, Ohio 45334-0729  
Phones: 1-800-999-3271 or 937-596-6713 FAX: 937-596-5145  
<http://www.prodeva.com> E-mail: [sbunke@prodeva.com](mailto:sbunke@prodeva.com)